

Crystal Structure of Cesium *trans*-Tetrachloroaquocarbonylruthenate(II)

J. A. Stanko and Surang Chaipayungpundhu

Contribution from the Department of Chemistry, The Pennsylvania State University, University Park, Pennsylvania 16802. Received May 12, 1970

Abstract: The crystal structure of the salt cesium tetrachloroaquocarbonylruthenate(II) has been solved by the conventional heavy-atom method using intensity data collected by counter techniques, and the structure has been refined to a conventional R factor of 0.050 for 712 reflections having $I \geq 2\sigma(I)$. The crystals of the salt $\text{Cs}_2[\text{RuCl}_4(\text{H}_2\text{O})\text{CO}]$ belong to the orthorhombic system and have cell dimensions $a = 8.096 \pm 0.003 \text{ \AA}$, $b = 17.190 \pm 0.010 \text{ \AA}$, and $c = 7.437 \pm 0.002 \text{ \AA}$. The space group is $Amam$ (no. 63) and there are four formula units in the unit cell. The coordination sphere about the ruthenium has the carbon monoxide and water ligands in a *trans* arrangement. The four chloride ligands lie in a plane, but at the corners of a rectangle instead of a square. The ruthenium atom is displaced slightly out of this plane and toward the carbon monoxide ligand. The important bond distances are $\text{Ru-CO} = 1.804 \pm 0.015$, $\text{Ru-OH}_2 = 2.245 \pm 0.011$, and $\text{Ru-Cl} = 2.395 \pm 0.002 \text{ \AA}$. The overall structure of the Ru(II) salt is remarkably similar to that of the Ru(III) salt, $\text{Cs}_2[\text{RuCl}_5(\text{H}_2\text{O})]$, but the Ru-OH_2 and Ru-Cl bonds in the Ru(II) complex are significantly longer than those in the Ru(III) complex. The possible implication of the latter fact with regard to the observed differences in catalytic effectiveness of the two complexes in promoting the hydration of acetylene to acetaldehyde is discussed.

We have determined the crystal structure of the cesium salt of the halocarbonylruthenium(II) complex, $\text{RuCl}_4(\text{H}_2\text{O})\text{CO}^{2-}$, as part of a study of the bonding and activation of carbon monoxide coordinated to heavy transition metal ions.^{1,2} The tetrachloroaquocarbonylruthenate(II) complex was discovered by Halpern, James, and Kemp³ in a study that was one of the first to demonstrate that solutions of simple halide complexes of the platinum group metals have the ability to bind carbon monoxide under relatively mild conditions to form mono- and dicarbonyl complexes. Since their synthesis of the ruthenium(III) and ruthenium(II) complexes, $\text{RuCl}_5\text{CO}^{2-}$, $\text{RuCl}_4(\text{H}_2\text{O})\text{CO}^{2-}$, and $\text{RuCl}_4(\text{CO})_2^{2-}$, we and others have isolated a similar rhodium(III) carbonyl, $\text{RhCl}_5\text{CO}^{2-}$,^{2,4} and detected the iridium(III) carbonyl, $\text{IrCl}_5\text{CO}^{2-}$,⁵ as intermediates in the reaction of carbon monoxide with solutions of the chloro complexes of these respective metal ions. Cleare and Griffith⁶ have extended this series of known monocarbonyl halide complexes to include those of osmium, and have shown that these and those of the other metals are readily synthesized *via* CO abstraction from formic acid.

The existence of such a broad series of related carbonyl complexes offers an unusual opportunity for a study of the variation of the bonding of carbon monoxide to metal ions as a function of the metal, its oxidation state, and possibly the other ligands in the coordination sphere. Thus it seems worthwhile to obtain detailed structural data on these complexes which will later be useful in correlating the variation in the chemical and spectroscopic properties of the complexes. For example, Table I gives a comparison of the observed values of the coordinated C-O stretching frequency in the series of known monocarbonyl com-

Table I. Infrared Data on Carbonyl Halides of the Platinum Metals^a

Compound	$\nu(\text{CO})$, cm^{-1}	$\Delta\nu(\text{CO})$, cm^{-1}
CO (free molecule)	2170	
$\text{Cs}_2[\text{Cl}_5\text{Rh-CO}]$	2117	53
$\text{Cs}_2[\text{Cl}_5\text{Ir-CO}]$	2060	110
$\text{Cs}_2[\text{Cl}_5\text{Ru-CO}]$	2015	155
$\text{Cs}_2[\text{Cl}_5\text{Os-CO}]$	1968	202
$\text{Cs}_2[\text{Cl}_4(\text{H}_2\text{O})\text{Ru-CO}]$	1951	221

^a Data taken from ref 6.

plexes, and the data seem to imply a wide variation of the metal-carbon bond strengths among the complexes, if in the usual sense this can be taken as proportional to the magnitude of the reduction of the coordinated CO frequency from that in free CO. The reduction is the largest for the $\text{RuCl}_4(\text{H}_2\text{O})\text{CO}^{2-}$ complex, implying the strongest metal-carbon bond of the series, and it was this fact along with the interesting catalytic properties³ of the complex which led us to investigate its structure initially. Some preliminary crystallographic data on the Ru(III) complex, $\text{RuCl}_5\text{CO}^{2-}$ were also obtained and are presented.

Experimental Section

Preparation of the Compound. The compound $\text{Cs}_2[\text{RuCl}_4(\text{H}_2\text{O})\text{CO}]$ was prepared according to the method of Halpern, *et al.*,³ in which a solution of the cesium salt of the ruthenium(III) complex, $\text{RuCl}_5\text{H}_2\text{O}^{2-}$, was carbonylated to form the monocarbonyl complex, $\text{RuCl}_5\text{CO}^{2-}$, which was then reduced with a stream of hydrogen gas to the ruthenium(II) carbonyl, $\text{RuCl}_4(\text{H}_2\text{O})\text{CO}^{2-}$. Green, dichroic prismatic crystals of the compound were grown by slow evaporation of the reduced solutions under nitrogen. The identification of the crystals as $\text{Cs}_2[\text{RuCl}_4(\text{H}_2\text{O})\text{CO}]$ was made by infrared spectroscopy and chemical analysis. *Anal.* Calcd: C, 2.16; H, 0.33. Found: C, 2.35; H, 0.36. The infrared spectrum of the solid in KBr showed bands at 3420, 1951, and 1610 cm^{-1} , which could be assigned to the O-H stretch, C-O stretch, and H-O-H bend, respectively, in the complex. These values compare well with those previously reported.⁶

Crystallographic Data. A single crystal of the compound was examined on precession and Weissenberg X-ray cameras and it exhibited *mmm* diffraction symmetry, indicating an orthorhombic lattice. The systematically absent reflections on the Weissenberg

(1) J. A. Stanko and T. W. Starinshak, *Inorg. Chem.*, **8**, 2156 (1969).

(2) J. A. Stanko, G. Petrov, and C. K. Thomas, *Chem. Commun.*, 1100 (1969).

(3) J. Halpern, B. R. James, and A. L. Kemp, *J. Amer. Chem. Soc.*, **88**, 5142 (1966).

(4) D. Forster, *Inorg. Chem.*, **8**, 2556 (1969).

(5) D. Forster, *Inorg. Nucl. Chem. Lett.*, **5**, 433 (1969).

(6) M. J. Cleare and W. P. Griffith, *J. Chem. Soc. A*, 372 (1969).

photographs of the zones $\{hkl\}$, $l = 0-8$, and precession photographs of the zones $\{h0l\}$ and $\{0kl\}$ were hkl for $k + l = 2n + 1$ and $h0l$ for $h = 2n + 1$, indicating an A -centered cell with an a glide plane perpendicular to the b axis. The possible space groups corresponding to these extinctions are $A2am$, $Ama2$, and $Amam$. The structure was solved and refined assuming the centric choice, $Amam$ (D_{2h}^{17} , no. 63).⁷ The unit cell dimensions obtained from a least-squares refinement of 2θ values for nine reflections measured on a Syntex four-circle diffractometer, using nickel-filtered copper radiation ($\lambda_{K\alpha} 1.5418 \text{ \AA}$), are $a = 8.096 \pm 0.003$, $b = 17.190 \pm 0.010$, and $c = 7.437 \pm 0.002 \text{ \AA}$. The observation that the crystal sank in methylene iodide (density of 3.3 g cm^{-3}) is consistent with a calculated density of 3.57 g cm^{-3} , based on four formula units per cell.

Morphology and Microscopy of the Crystals. The crystals grow as green prisms elongated along the $[001]$ direction and bounded by sides parallel to this direction of the form $\{120\}$. The crystals exhibit quite striking dichroism. For polarized light propagated along the $[001]$ direction (*i.e.*, looking down the long axis of the crystals), the crystal appears green when the polarization is parallel to the a crystal axis and yellow-brown when parallel to the b axis. For light propagated along the $[100]$ direction, the crystals are yellow-brown when the polarization is parallel to b , and green when parallel to c . For propagation in the $[010]$ direction the crystals appear green for either polarization along a or c . These observations are consistent with the structural result found below, that there is a high degree of alignment of the Ru-CO axes of the anions in the cell, parallel to the b crystal axis, and that the dichroism is associated with the polarized nature of the electronic transitions relative to this molecular axis.

Collection of X-Ray Intensity Data. The intensity data were collected initially by film methods on a Weissenberg camera, and though the structure was solved on the basis of these data originally, the large standard deviation in the coordinates and temperature factors of the CO and H₂O ligands indicated that more precise intensity data would be needed if any meaningful bond distances for these atoms in the coordination sphere were to be obtained. Thus, an improved data set was collected on a recently acquired Syntex four-circle autodiffractometer.

A prismatic crystal of maximum dimensions $0.02 \times 0.02 \times 0.05$ mm in the directions of the a , b , and c unit cell axes, respectively, was mounted and aligned with its c axis coincident with the ϕ axis of the diffractometer. Because of the large absorption coefficient of this crystal for copper radiation ($\mu = 766 \text{ cm}^{-1}$), zirconium-filtered molybdenum radiation ($\lambda_{K\alpha} 0.7107 \text{ \AA}$), for which μ was 100 cm^{-1} , was used in the data collection. A ϕ scan, made on the 002 reflection at $\chi = 90^\circ$, showed no deviation of intensity, and implied that any absorption effect due to anisotropy in the shape of the crystal was minimal. A takeoff angle of 4° , which gave an approximately square focal spot when viewed with the Samson-type image caster,⁸ was used in conjunction with a 1-mm diameter incident beam collimator and a 2-mm diameter circular receiving aperture on the diffracted beam side. (In our system the filtering of the X-rays is done on the incident beam side.) The crystal-to-source and crystal-to-counter distances were both 13.5 cm. The diffracted beam intensities were measured with a scintillation counter equipped with preamplifier and pulse-height analyzer. The settings for the PHA window width and gain were determined from a pulse-height distribution curve prepared from the 002 reflection from the crystal.

All reflections (except those extinguished by the A centering) in one octant ($+h, +k, +l$) of reciprocal space having $2\theta(\text{Mo K}\alpha) < 60^\circ$ ($d_{\text{min}} = 0.7107 \text{ \AA}$) were collected using a θ - 2θ scan technique. A symmetrical scan range of -1.0 to $+1.0$ from the calculated 2θ position was used. The scan rate was $1^\circ/\text{min}$ and stationary background counts of 15-sec duration were taken at each end of the scan. A single check reflection (202) was remeasured after every 26 reflections (2 hr) to check on instrumental and crystal stability. The fluctuation of its intensity over the entire data collection period was only $\pm 2\%$.

The measured intensities were corrected for background using the linear assumption for the latter which leads to the formula $I = [S - (B_1 + B_2)t/30]$, where S is the scan count, B_1 and B_2 are the fixed-time background counts, t is the time, in seconds, spent on

the scan, and 30 (sec) is the time spent on the background. Standard deviations $\sigma(I)$ were assigned to the corrected intensities using the formula $\sigma(I) = [S + (B_1 + B_2)(t/30)^2 + 0.02S^2]^{1/2}$, where the symbols have the meaning given previously, and the factor 0.02 is an empirical parameter introduced to account for uncertainties in the measurements other than those due to counting statistics.⁹ Of the 878 reflections measured, 712 had $I \geq 2\sigma(I)$ and these were corrected for Lorentz and polarization effects and used in the solution and subsequent refinement of the structure.

Solution and Refinement of the Structure

An initial clue to the structure of the $\text{Cs}_2[\text{RuCl}_4(\text{H}_2\text{O})\text{CO}]$ salt was given by the observed close similarity in cell dimensions, space group, and powder pattern of the salt to those of $\text{Cs}_2[\text{RuCl}_5(\text{H}_2\text{O})]$, whose structure has been reported recently by Hopkins, Zalkin, Templeton, and Adamson.¹⁰ With four formula units of $\text{Cs}_2[\text{RuCl}_4(\text{H}_2\text{O})\text{CO}]$ in a unit cell with 16 general positions, $Amam$ (no. 63), the Ru atoms, the C and O atoms of the carbonyl ligands, and the O atoms of the water ligands are required to lie on a set of fourfold special positions, in the absence of any disorder. A three-dimensional Patterson function computed from the observed structure factors estimated from the film data showed a substantial peak along the Harker line $P(1/2, v, 0)$ which would be consistent with a vector between ruthenium atoms in the set, $4c$, of fourfold special positions of the space group. The appearance of several additional moderately intense peaks along this line, and along the line $P(0, v, 0)$ indicated that the eight Cs^+ ions must also be occupying the set $4c$. An internally consistent assignment of these additional peaks as Ru-Cs and Cs-Cs (the latter were weaker than the former) vectors enabled the coordinates of the Ru, Cs(1), and Cs(2) atoms of the asymmetric unit to be derived. The 16 chloride anions in the cell were assigned to the set of 16-fold general positions, $16h$, on the basis of the interpretation of a substantial peak on the section $P(u, 0, w)$ as a bonded Ru-Cl vector. This assignment implies that the four chloride ligands are arranged in an equatorial plane about the ruthenium.

A structure factor calculation based on the Ru, Cl, Cs(1), and Cs(2) atom coordinates obtained from the Patterson map and using an overall isotropic temperature factor of 3.0 \AA^2 gave a value of 0.37 for the discrepancy index, R_1 , defined as $R_1 = \sum ||F_o| - |F_c|| / \sum |F_o|$. The X-ray scattering curves for these and subsequent calculations were taken from the following sources: Ru^{2+} and Cs^+ from Thomas and Umeda¹¹ and Cl^- , C^0 , and O^0 from the compilation of Ibers.¹² Two cycles of least-squares refinement¹³ of the atom coordinates, individual isotropic temperature factors, and an overall scale factor reduced R_1 to 0.17. The function minimized was $\sum w(|F_o| - |F_c|)^2$, where the weights, w , were taken as unity initially. An electron density Fourier map phased on the above atoms was computed¹⁴ at this stage and revealed the carbon and

(9) S. W. Peterson and H. A. Levy, *Acta Crystallogr.*, **10**, 70 (1957).

(10) T. E. Hopkins, A. Zalkin, D. H. Templeton, and M. G. Adamson, *Inorg. Chem.*, **5**, 1427 (1966).

(11) L. H. Thomas and K. Umeda, *J. Chem. Phys.*, **26**, 295 (1957).

(12) J. A. Ibers in ref 7, Vol. III, 1962, pp 201-207.

(13) Using the program ORFLS: W. R. Busing, K. O. Martin, and H. A. Levy, "A Fortran Crystallographic Least Squares Program," Oak Ridge National Laboratory, Oak Ridge, Tenn.

(14) Fourier computations were performed with the program B-149 (Argonne National Laboratory), a version of Shoemaker, Sly, and Van den Hende's ERFR-2, by J. Gvildys.

(7) "International Tables for X-ray Crystallography," Vol. I, The Kynoch Press, Birmingham, England, 1952, p 152.

(8) S. Samson and W. W. Schuelke, *Rev. Sci. Instrum.*, **38**, 1272 (1967).

oxygen atoms of the CO ligand and the oxygen of the water ligand in a *trans* position about the Ru atom along the *y* axis (positions 4c). With the addition of these three atoms to the structure, two more cycles of isotropic refinement converged to a value of R_1 of 0.11. However, the standard deviation in the coordinates and temperature factors of the C and O atoms of the carbonyl group and the O atom of the water were very large. Also distances computed for the Ru-C, C-O, and Ru-O(H) bonds lengths did not seem realistic and it was at this point that more precise intensity data were collected with the diffractometer.

The final parameters from the film data refinement were used as a starting point for a set of least-squares calculations based on the new intensity data. After two cycles of isotropic refinement, R_1 decreased to 0.081 and the C, O(C), and O(H) isotropic temperature factors and coordinates, and the bond lengths computed from the latter, now looked considerably more reasonable. Up to this point, a unit weight scheme had been employed in the refinement. This was changed to one where the weights were assigned as $w = 1/\sigma^2(F_o)$, where $\sigma(F_o)$ is the standard deviation of the structure factor and is related to the standard deviations of the intensities, $\sigma(I)$, by the formula $\sigma(F_o) = 0.5(\sigma(I))(LP^{-1}/I)^{1/2}$.¹⁵ In addition, one intense reflection, 202, which was either suffering from extinction or had exceeded the linear range of the counter, was given zero weight. Using this weighting scheme, two further cycles of isotropic refinement reduced the values of R_1 and R_2 to 0.076 and 0.074, respectively, where R_2 is now the weighted discrepancy index defined as $R_2 = [\sum w(|F_o| - |F_c|)^2 / \sum w|F_o|^2]^{1/2}$. All seven atoms in the asymmetric unit were next allowed anisotropic thermal parameters, and after three cycles, R_1 and R_2 converged to values of 0.050 and 0.046, respectively, for the 715 observed reflections, and the final value of the "goodness of fit" $[\sum w(|F_o| - |F_c|)^2 / (NO - NV)]^{1/2}$ was 2.00. A "difference" Fourier map computed at this stage failed to give any clear indication of the hydrogen atoms on the water ligand; however, it did contain one unanticipated feature in the form of a small peak on the far side of the water oxygen with coordinates $x = 0.2500$, $y = -0.0465$, and $z = 0.000$. The coordinates of this peak compare well with those of the oxygen of the CO ligand if the CO and H₂O positions in the coordination sphere along the *y* axis were reversed. From the height of this peak in the "difference" map compared to that of the carbonyl oxygen in the electron density maps, it could be estimated that about 10% reversal of the (H)O-Ru-C-O axes of the complexes occurs in the crystal. Thus in a final round of least-squares calculations a disordered model was assumed. The original C, O(C), and O(H) atoms were given an occupancy factor α , and a new set of atoms C', O'(C'), and O'(H) were introduced, with coordinates corresponding to the reversed orientation and restricted to an occupancy factor $1 - \alpha$. The coordinates, anisotropic temperature parameters, overall scale factor, and occupancy factor of the seven independent atoms of the asymmetric unit were then refined, with the three new atoms C', O'(C'), and O'(H) constrained to having the same

temperature factors and distances from the ruthenium as their related atoms. The refinement converged in two cycles with no change in the values R_1 and R_2 . The parameter changes which occurred resulted in a slight lengthening of the C-O bond and a slight shortening of the Ru-O(H) bond from these lengths in the undisordered model. The final value of the occupancy parameter α was only 0.98. Another difference map was computed at this stage and was found to be essentially featureless; presumably, the disorder was accounted for satisfactorily. Tables II and III list

Table II. Atomic Coordinates from Least-Squares Refinement^a

Atom	<i>x</i>	<i>y</i>	<i>z</i>
Cs(1)	0.2500 ^b	0.4781 (0.6)	0.0 ^b
Cs(2)	0.2500 ^b	0.7551 (0.6)	0.0 ^b
Ru	0.2500 ^b	0.1219 (0.6)	0.0 ^b
Cl	0.4616 (2)	0.1162 (1)	0.2246 (2)
C	0.2500 ^b	0.2268 (9)	0.0 ^b
O(C)	0.2500 ^b	0.2902 (9)	0.0 ^b
O(H)	0.2500 ^b	-0.0087 (6)	0.0 ^b

^a In fractions of the unit cell edge. Estimated standard deviations ($\times 10^4$) of least significant figure are given in parentheses.

^b Coordinate in special position by symmetry requirement.

Table III. Anisotropic Thermal Parameters ($\times 10^4$)^a for Cs₂[RuCl₄(CO)(H₂O)]

Atom	β_{11}	β_{22}	β_{33}	β_{12}	β_{13}	β_{23}
Cs(1)	64 (2)	15 (0.3)	130 (2)	0 ^b	0 ^b	0 ^b
Cs(2)	107 (2)	17 (0.3)	105 (2)	0 ^b	0 ^b	0 ^b
Ru	45 (1)	10 (0.3)	57 (2)	0 ^b	0 ^b	0 ^b
Cl	63 (2)	21 (1)	82 (3)	-1 (1)	-30 (2)	10 (1)
C	33 (20)	13 (4)	6 (19)	0 ^b	0 ^b	0 ^b
O(C)	165 (35)	30 (7)	190 (41)	0 ^b	0 ^b	0 ^b
O(H)	90 (23)	4 (3)	297 (40)	0 ^b	0 ^b	0 ^b

^a Anisotropic temperature parameters are expressed in the form $\exp[-(h^2\beta_{11} + k^2\beta_{22} + l^2\beta_{33} + 2hk\beta_{12} + 2hl\beta_{13} + 2kl\beta_{23})]$. The estimated deviations are in parentheses. ^b Constrained to zero by symmetry requirement.

the final atomic coordinates and thermal parameters, respectively, obtained from the least-squares refinement with the inclusion of disorder, and Table IV lists the observed structure factors and those calculated from the parameters in Tables II and III. The scale factor for the structure factor table to place the data in electrons is 1/1.126.

Results and Discussion

The significant structural features we find for the tetrachloro-aquocarbonylruthenate(II) complex are that it is a *trans* complex and the overall structure of its cesium salt is remarkably similar to that of the same salt of the pentachloro-aquoruthenate(III) complex.¹⁰ The cells of the two structures are formally related by replacement of a chloride ligand *trans* to the water molecule in the Ru(III) complex by a carbon monoxide ligand in the Ru(II) complex. A perspective drawing of the unit cell of the Cs₂[RuCl₄(H₂O)CO] salt viewed down the *c* crystal axis is shown in Figure 1. For clarity, only two of the four formula units ($z = 0-1/2$) are shown; the omitted half of the cell may be obtained through the *A*-centering operation of the space group (*Amam*). Figure 2 shows the structure viewed down the *a* crystal axis and more clearly

(15) G. H. Stout and L. H. Jensen, "X-ray Structure Determinations," Macmillan, New York, N. Y., 1968, p 457.

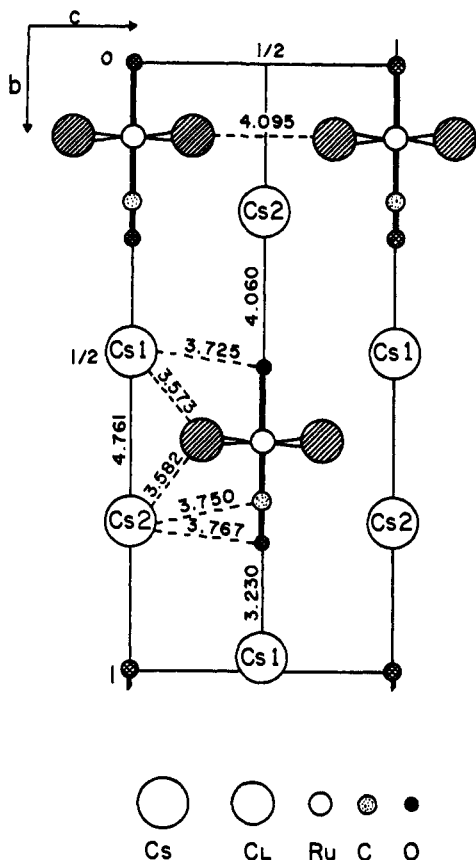

Figure 2. Projection of the structure of $\text{Cs}_2[\text{RuCl}_4(\text{H}_2\text{O})\text{CO}]$ down the a crystal axis. All atoms in the figure have an x coordinate of 0.2500, with the exception of the chlorides (shown superimposed) which have x coordinates of 0.4614 and 0.0384. For clarity, only two of the four formula units in the cell are shown. The omitted two may be derived through the operation of the a glide plane of the space group (Amm) at $y = 0$ and $1/2$.

Table V. Distances (≤ 5.00 Å) in $\text{Cs}_2[\text{RuCl}_4(\text{H}_2\text{O})\text{CO}]^i$

(A) Intramolecular			
Ru-C	1.804 (15)	Cl-Cl	3.342 (3)
Ru-O(H)	2.245 (11)	Cl-Cl	3.427 (3)
Ru-Cl	2.395 (2)	Cl-O(C)	3.831 (12)
Ru-O(C)	2.894 (15)	Cl-Cl	4.786 (3)
C-O(C)	1.091 (21)	C-O(H)	4.048 (18)
Cl-C	3.056 (10)		
Cl-O(H)	3.215 (7)		
(B) Intermolecular			
Cs(1)-O(C)	3.230 (15)	Cs(2)-C ^d	4.060 (1)
Cs(1)-Cl ^a	3.503 (2)	Cs(2)-O(C) ^d	4.122 (3)
Cs(1)-Cl ^b	3.573 (2)	Cs(2)-Ru ^c	4.367 (1)
Cs(1)-O(H) ^b	3.725 (1)	Cs(2)-Ru ^d	4.567 (1)
Cs(1)-Cs(1) ^d	4.117 (1)		
Cs(1)-C	4.321 (15)	Cl-O-(H) ^f	3.414 (6)
Cs(1)-Ru ^c	4.465 (1)	Cl-O(C) ^g	3.497 (6)
Cs(1)-Cs(2)	4.761 (14)	Cl-Cl ^h	4.043 (4)
		Cl-Cl ^h	4.095 (4)
Cs(2)-Cl ^b	3.582 (2)	Cl-C ^g	4.115 (4)
Cs(2)-Cl ^d	3.624 (2)	Cl-Cl ^g	4.667 (4)
Cs(2)-C ^c	3.750 (2)	Cl-Cl ⁱ	4.669 (4)
Cs(2)-O(C) ^c	3.767 (2)		
Cs(2)-O(H) ^e	4.060 (11)	O(H)-O(H)	4.059 (1)

^a $-x, 1/2 - y, 1/2 - z$. ^b $x, 1/2 + y, 1/2 - z$. ^c $x, 1/2 + y, 1/2 + z$. ^d $1/2 + x, 1 - y, z$. ^e $x, 1 - y, z$. ^f $1/2 + x, -y, z$. ^g $1/2 + x, 1/2 - y, 1/2 - z$. ^h $x, y, 1 - z$. ⁱ $3/2 - x, y, z$. ^j Standard deviations of the least significant digits are given in parentheses.

ligand, the central ruthenium atom, and the carbon and oxygen atoms of the carbonyl ligand to be in a

Table VI. Bond Angles (deg) in $\text{Cs}_2[\text{RuCl}_4(\text{H}_2\text{O})\text{CO}]^a$

Cl-Ru-C	92.3 (1)	Cs(1)-O(H)-Ru	93.4 (1)
Cl-Ru-O(H)	87.7 (1)	Cs(2)-C-Ru	97.5 (2)
Cl-Ru-Cl	91.35 (7)	Cs(2)-O(C)-C	80.78 (4)
Cl-Ru-Cl	88.46 (6)	Cs(2)-C-Ru	94.4 (2)
		Cs(2)-O(C)-C	79.1 (4)

^a Standard deviations of the least significant digits are given in parentheses.

strictly linear arrangement at the intersection of two perpendicular mirror planes. The mirror planes bisect the Cl-Ru-Cl bond angles. The four equatorial chloride ligands lie in a plane perpendicular to the two-fold axis of the complex but at the corners of a rectangle instead of a square, the independent Cl-Ru-Cl bond angles being 88.5 (1) and 91.4 (1)°. The ruthenium atom is displaced slightly out of the plane of the chloride ligands (0.097 Å) and toward the carbon monoxide ligand. Hopkins, Zalkin, Templeton, and Adamson's¹⁰ interpretation of a similar orthorhombic distortion of the equatorial chloride ligands about the Ru(III) atom in the $\text{RuCl}_5\text{H}_2\text{O}^{2-}$ complex (Figure 3b) as being a result of preferential hydrogen bonding between a water molecule and chloride ligands (having the smaller of the two independent Cl-Ru-Cl bond angles) of neighboring complexes, seems to be supported by the near-identical distortion in the ruthenium(II) aquocarbonyl salt.¹⁷ The O(H)-Cl hydrogen bonding distance between the oxygen of a water molecule and the chloride ligand of neighboring complexes in the Ru(II) salt was found to be 3.414 (6) Å.

The ruthenium-carbonyl-carbon bond length, Ru(II)-C, of 1.80 (1) Å in the tetrachloro-aquocarbonyl-ruthenate(II) complex is among the shortest reported for ruthenium carbonyls and is nicely consistent with the predicted strong ruthenium-carbon bond on the basis of the infrared data for the complex (Table I). The only octahedral carbonyl halides of the platinum group metals for which structural data are available for comparison are the compounds $\text{K}_2[\text{IrBr}_5\text{CO}]$ ¹⁸ and *cis*- $\text{RuI}_2(\text{CO})_4$.¹⁹ In the iridium compound the carbonyl ligand was not precisely located, but in the ruthenium compound the observed average Ru(II)-C distance for the carbonyl groups was 2.01 (6) Å, which is considerably longer than in the $\text{RuCl}_4(\text{H}_2\text{O})\text{CO}^{2-}$ complex, though the reported standard deviations of these distances are rather large in the iodotetracarbonyl complex. Ru-C distances in the range 1.81–1.92 Å have been observed among organometallic ruthenium carbonyls,²⁰ and the variations in the distances have been correlated with the π -acceptor ability of the ligands other than CO in the coordination sphere. Since chloride and water ligands are known to be poor π

(17) In this regard, it would be useful to have structural data on the chlororuthenium complex $\text{RuCl}_5\text{CO}^{2-}$ not containing a coordinated water molecule. To this end we have examined the salt $\text{Cs}_2[\text{RuCl}_5\text{CO}]$, which crystallizes in the cubic system, space group $Fm\bar{3}m$ (O_h , no. 225), with cell dimension $a = 10.25$ (4) Å, $Z = 4$, $D_c = 3.49$ g cm⁻³, $D_m > 3.3$ g cm⁻³. These data suggest that the CO group, unfortunately, is randomly oriented among the six coordination sites of the Ru atom in the crystal, which will preclude the possibility of obtaining useful bond angle or distance information on the complex from this salt. Other salts of the $\text{RuCl}_5\text{CO}^{2-}$ complex are presently being examined.

(18) M. Bonamico, D. Duranti, A. Vacicago, and L. Zamborelli, *Ric. Sci., Parte 2*, 7, 613 (1964).

(19) L. F. Dahl and D. L. Wampler, *Acta Crystallogr.*, 15, 946 (1962).

(20) F. A. Cotton and R. Eiss, *J. Amer. Chem. Soc.*, 91, 6593 (1969); F. A. Cotton and W. T. Edwards, *ibid.*, 90, 5412 (1968); M. J. Bennett, F. A. Cotton, and P. Legzdins, *ibid.*, 90, 6335 (1968).

acceptors, the CO ligand in the $\text{RuCl}_4(\text{H}_2\text{O})\text{CO}^{2-}$ complex should be able to accept rather more metal π -electron density, thereby increasing the Ru–C bond order and shortening the Ru–C bond length, relative to complexes which contain ligands which can more effectively compete with CO for metal electron density.

The observed carbon–oxygen distance of 1.09 (2) Å for the coordinated CO ligand in the $\text{RuCl}_4(\text{H}_2\text{O})\text{CO}^{2-}$ complex is within 2 esd's of that in the free molecule (1.128 Å), but seems to be shorter than the value of 1.18 Å commonly reported for C–O distances in metal carbonyls. However, Dahl and Wampler¹⁹ report a similar short C–O distance of 1.05 (6) Å in the $\text{RuI}_2(\text{CO})_4$ complex, the only other ruthenium carbonyl halide for which structural data are available. Some of the apparent shortness of the C–O length in the complex studied here may be a result of thermal motion,²¹ since from the observed thermal parameters for the terminal oxygen atom of the CO group, it appears to be undergoing some amount of librational motion.

A comparison of the ruthenium–chloride and the ruthenium–water oxygen bond lengths in the tetrachloroaquocarbonylruthenate(II) complex with those bonds in the related pentachloroaquoruthenate(III) complex (Figures 3a and 3b) reveals a significant lengthening of these bonds in the lower oxidation state ruthenium complex. This subject of the change in metal–ligand bond length for complexes with the metal ion in different oxidation states is of some interest and has been discussed recently with regard to Co(II), Co(III) ammine²² and Ru(II), Ru(III) ammine complexes.²³ Comparing the equatorial Ru–Cl bond lengths of 2.353 (4) Å in the $\text{RuCl}_5(\text{H}_2\text{O})^{2-}$ complex and 2.395 (2) Å in the $\text{RuCl}_4(\text{H}_2\text{O})\text{CO}^{2-}$ complex, the increase in length for the Ru(II) complex is 0.042 Å. This is the order of magnitude of bond lengthening observed for the Ru–NH₃ bonds in the Ru(III), Ru(II) amines and presumably reflects the larger ionic radius of the d⁶ Ru(II) ion compared to the d⁵ Ru(III) ion. Our value, 2.395 (2) Å, for the Ru(II)–Cl distance in the carbonyl complex compares favorably with that of 2.415 (3) Å for this distance in the Ru(II) complex $[\text{Ru}(\text{NH}_3)_3\text{Cl}(\text{SO}_2)]^+$,²⁴ and likewise the available data on Ru(III)–Cl bond lengths in other chlororuthenium(III) complexes such as $\text{RuCl}_4(\text{H}_2\text{O})_2^-$ (2.34 (1) Å) and RuCl_6^{3-} (2.375 (2) Å) are consistent with this bond being on the average shorter than a Ru(II)–Cl bond.^{25,26}

If from the above discussion it can be presumed that the order of magnitude of lengthening of a Ru–ligand bond due to ionic radius changes in going from a Ru(III) to a Ru(II) complex is about 0.05 Å,

(21) W. R. Busing and H. A. Levy, *Acta Crystallogr.*, **17**, 142 (1964).

(22) T. Barnet, B. M. Craven, H. C. Freeman, N. E. Kime, and J. A. Ibers, *Chem. Commun.*, 307 (1966).

(23) H. M. Cleary and J. A. Ibers, Abstracts, Winter Meeting of the American Crystallography Association, Tulane University, March 1970, Abstract C10.

(24) L. H. Vogt, J. L. Katz, and S. E. Wiberly, *Inorg. Chem.*, **4**, 1157 (1965).

(25) T. E. Hopkins, A. Zalkin, D. H. Templeton, and M. G. Adamson, *ibid.*, **5**, 1427 (1966).

(26) T. E. Hopkins, A. Zalkin, D. H. Templeton, and M. G. Adamson, *ibid.*, **8**, 2421 (1969).

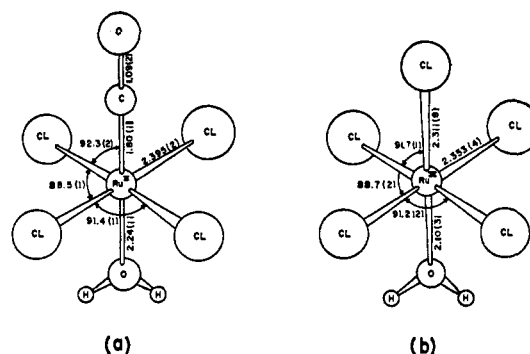

Figure 3. Bond angles and distances and their standard deviations (in parentheses) for the $\text{RuCl}_4(\text{H}_2\text{O})\text{CO}^{2-}$ complex (a) from present work, and the $\text{RuCl}_5\text{H}_2\text{O}^{2-}$ complex (b) from ref 10.

then to account for the observed increase of the ruthenium–water bond length of 0.14 Å in the $\text{RuCl}_4(\text{H}_2\text{O})\text{CO}^{2-}$ complex (Ru(II)–O = 2.24 (1) Å) compared to the $\text{RuCl}_5\text{H}_2\text{O}^{2-}$ complex (Ru(III)–O = 2.10 (3) Å), one must suppose a significant contribution to bond lengthening due to the *trans* effect of the carbon monoxide ligand in the Ru(II) complex. A possible further implication of these significantly differing metal–water distances in the two ruthenium complexes is with regard to the interpretation of their widely differing catalytic activities in promoting the hydration of acetylene to acetaldehyde. James and Rempel²⁷ and Halpern, James, and Kemp³ have demonstrated the importance of a coordinated water molecule for a metal complex to exhibit any catalysis of the hydration reaction, and they have shown³ the ruthenium(III) complex $\text{RuCl}_5(\text{H}_2\text{O})^{2-}$ to be nearly eight times more effective a catalyst than the $\text{RuCl}_4(\text{H}_2\text{O})\text{CO}^{2-}$ complex. Since the active species in the catalysis of the hydration reaction is thought to be a metal hydroxo complex, M–OH, which results from the ionization of a proton from a coordinated water molecule, the catalytic power of a complex might be expected to be related to the concentration of this species and hence to the acidity of the metal–aquo complex. On a qualitative basis, the acidity of metal–aquo complexes is expected to be proportional to the metal–oxygen *bond strength*, which in similar complexes might be reflected by the metal–oxygen *bond length*. Then judging from the increased Ru–O distance in the Ru(II) complex compared to the Ru(III) complex, the former complex would be expected to contain a less polarized—and hence less acidic—water molecule, which, from the above argument, would imply it should be a less effective catalyst, as is observed.

Acknowledgments. We thank Mr. Richard Adams for the unit cell and space group determination of the $\text{Cs}_2[\text{RuCl}_5\text{CO}]$ complex, and Miss Marguerite Yevitz for helpful assistance at various stages. The diffractometer used in the study was purchased through the combined financial resources of the Office of the Vice President for Research, The College of Science, and The Chemistry Department of The Pennsylvania State University.

(27) B. R. James and G. L. Rempel, *J. Amer. Chem. Soc.*, **91**, 363 (1969).